

# Icon Valves & Engineering Pvt. Ltd.

www.flushbottomvalve.net; fbv@ivevalves.com



## JACKETED FLUSH TANK BOTTOM VALVE ACTUATED FLANGE ENDS DISC OPENING INTO THE VALVE SHORT HUB 150#

NOTE: This Drawing, Catalogue, Photographs & Information there off are sole & Exclusive Property of 'IVE'. Icon Valves & Engineering Pvt. Ltd. Mumbai. It cannot be Copied, Distributed or Circulated to any other firm. Party or Individual without written consent from us. We keep our rights reserved to make any changes time to time in technical specification & dimension without prior notice. The dimensions, Drawing & Photographs illustrated are approximate & may some time differ from the actual product. Please ask for final Drawings & Photos against orders.

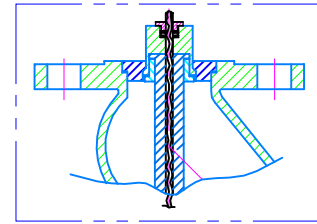
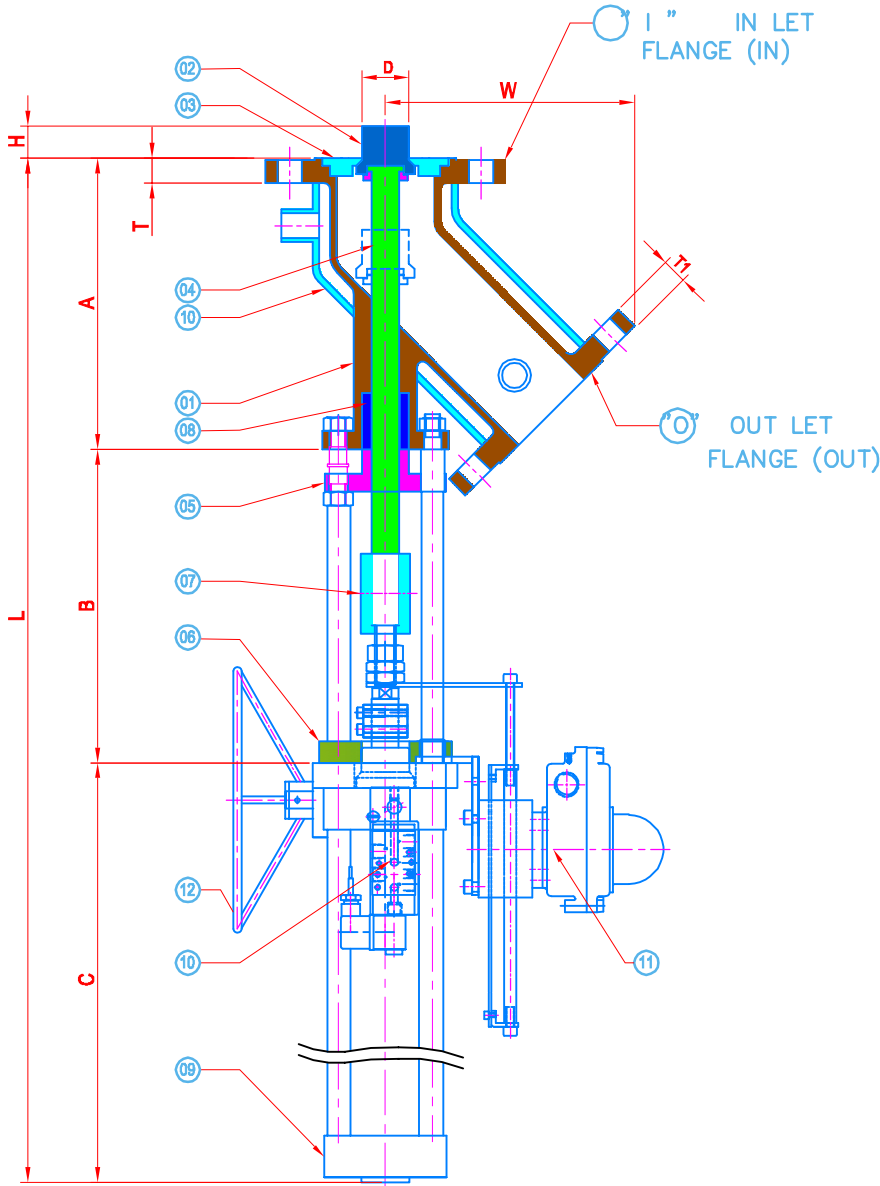

**PROVISION RTD SENSOR**



SR NO.	DESCRIPTION	MATERIAL	QTY.
01	BODY	ASTM A216 WCB, ASTM A351 / CF8 / CF8M / CF3 / CF3M / CN7M	1
02	DISC	AISI SS 304 / SS 316 / SS 304L / SS 316L / ALLOY 20	1
03	SEAT	AISI SS 304 / SS 316 / SS 304L / SS 316L / ALLOY 20	1
04	STEM	AISI SS 304 / SS 316 / SS 304L / SS 316L / ALLOY 20	1
05	GLAND	CS / CF 8	1
06	MOUNTING PLATE	MS / SS	1
07	COUPLER	MS / SS	1
08	GLAND PACKING	PTFE/GF/CF PTFE WITH PTFE ROPE / GRAPHOIL	1
09	PNEUMATIC CYLINDER	ALUMINIUM DIE CAST BODY S / A or D / A	1
10	LIMIT SWITCH	ALUMINIUM DIE CAST BODY	1
11	SOLENOID VALVE	ALUMINIUM DIE CAST BODY 3/2 OR 5/2 WAY	1
12	MANUAL OVER RIDE	CI BODY	1

PRIMARY SERVICE RATING & TEST PRESSURE				
CLASS	WORKING PRESS.	HYD. TEST PRESSURE		
		BODY	SEAT	TEMP.
150	150 PSIG	425 PSIG	300 PSIG	38° C
AIR TEST - SEAT		80 PSIG ±10 PSIG		
TECHNICAL DATA				
DESIGN & MANUFACTURING STD.		MANUFACTURERS STD. / ANSI B-16.34		
TESTING & INSPECTION STD.		API 598		
END CONNECTIONS :		FLANGED AS PER ANSI B-16.5 CLASS-150#.		

JACKETED FLUSH TANK BOTTOM VALVE ACTUATED FLANGE ENDS DISC OPENING INTO THE VALVE												
SIZE (mm)	APPROX L = A+B+C	H	D	W	A	B	C	(FLANGE DIMENSIONS) I	T	(FLANGE DIMENSIONS) O	T1	APP. WT. / KG FOR VALVE ONLY
1"	1"			134	153			AS PER 1" NB ASA 150#	11	AS PER 1" NB ASA 150#	11	10
1.1/2"	1.1/2"			177	175			AS PER 1.1/2" NB ASA 150#	14	AS PER 1.1/2" NB ASA 150#	14	11
2"	2"			178	187			AS PER 2" NB ASA 150#	16	AS PER 2" NB ASA 150#	16	14
3"	3"			204	237			AS PER 3" NB ASA 150#	19	AS PER 3" NB ASA 150#	19	27
4"	4"			240	296			AS PER 4" NB ASA 150#	24	AS PER 4" NB ASA 150#	24	38
6"	6"			321	415			AS PER 6" NB ASA 150#	25	AS PER 6" NB ASA 150#	25	70