

# Icon Valves & Engineering Pvt. Ltd.

www.flushbottomvalve.net; fbv@ivevalves.com

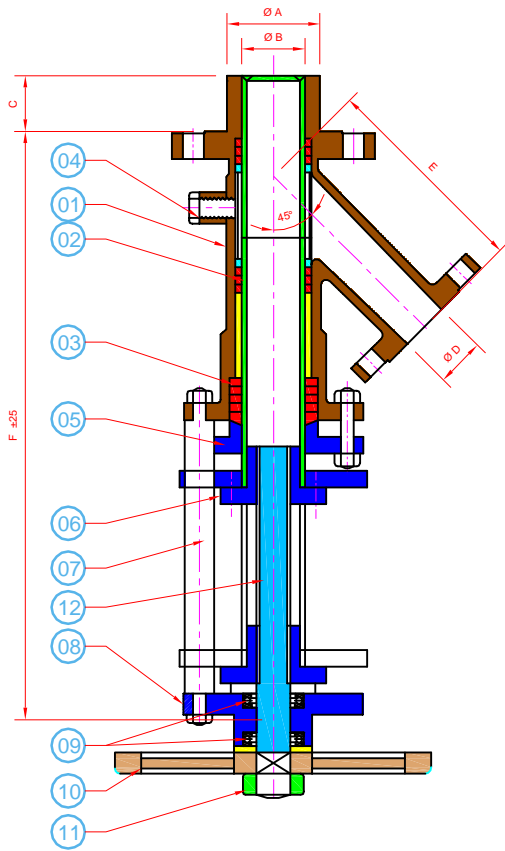

## PISTON / RAM TYPE FLUSH TANK BOTTOM VALVE FLANGE ENDS 150# MANUAL



| VALVE SIZE | A                         | B                         | C                         | D   | E ±5 | F   |
|------------|---------------------------|---------------------------|---------------------------|-----|------|-----|
| 20 X 20    | TO BE SPECIFIED BY CLIENT | TO BE SPECIFIED BY CLIENT | TO BE SPECIFIED BY CLIENT | 20  | 125  | 450 |
| 25 X 25    |                           |                           |                           | 25  | 140  | 530 |
| 40 X 25    |                           |                           |                           | 25  | 140  | 530 |
| 40 X 40    |                           |                           |                           | 32  | 200  | 560 |
| 50 X 40    |                           |                           |                           | 32  | 200  | 560 |
| 50 X 50    |                           |                           |                           | 50  | 200  | 700 |
| 80 X 50    |                           |                           |                           | 50  | 200  | 700 |
| 80 X 80    |                           |                           |                           | 76  | 240  | 750 |
| 100 X 80   |                           |                           |                           | 76  | 240  | 750 |
| 100 X 100  |                           |                           |                           | 102 | 300  | 830 |
| 150 X 100  |                           |                           |                           | 102 | 300  | 830 |
| 150 X 150  |                           |                           |                           | 152 | 400  | 950 |

| SR. NO. | DESCRIPTION           | QTY | MATERIAL                 |
|---------|-----------------------|-----|--------------------------|
| 1       | BODY                  | 1   | ASTM A GR 351 CF8M / CF8 |
| 2       | PLUNGER               | 1   | AISI S S 316 / 304       |
| 3       | GLAND PACKING         | 6   | PTFE / GFT / CFT         |
| 4       | DRAIN PLUG            | 1   | AISI S S 316             |
| 5       | GLAND                 | 1   | S S 316 / 304 / CF8      |
| 6       | PLUNGER DRIVE BUSHING | 1   | BRASS / EN 1 A           |
| 7       | YOKE POST / PILLER    | 1   | S S 316 / 304 / CF8      |
| 8       | YOKE HOUSING          | 1   | S S 316 / 304 / CF8      |
| 9       | BEARING SET           | 1   | THRUST RADIAL            |
| 10      | HAND WHEEL            | 1   | S S 304 / CF8 / C I      |
| 11      | HAND WHEEL NUT        | 1   | S S 316 / 304 / CF8      |
| 12      | STEM                  | 1   | AISI S S 316             |

### PRIMARY SERVICE RATING & TEST PRESSURE

| CLASS           | WORKING PRESS. | HYD. TEST PRESSURE |          |       |
|-----------------|----------------|--------------------|----------|-------|
|                 |                | BODY               | SEAT     | TEMP. |
| 150             | 150 PSIG       | 425 PSIG           | 300 PSIG | 38° C |
| AIR TEST - SEAT |                | 80 PSIG ±10 PSIG   |          |       |

### TECHNICAL DATA

|                             |                                       |
|-----------------------------|---------------------------------------|
| DESIGN & MANUFACTURING STD. | MANUFACTURERS STD. / ANSI B-16.34     |
| TESTING & INSPECTION STD.   | API 598                               |
| END CONNECTIONS             | FLANGED AS PER ANSI B-16.5 CLASS-150# |

NOTE: This Drawing, Catalogue, Photographs & Information there off are sole & Exclusive Property of "IVE", Icon Valves & Engineering Pvt. Ltd. Manual. It cannot be Copied, Distributed or Circulated to any other firm, Party or individual without written consent from us. We keep our rights reserved to make any changes time to time in technical specification & dimension without prior Notice. The dimensions, Drawing & Photographs illustrated are approximate & may some time differ from the actual product. Please ask for final Drawings & Photos against order.